

DEEP GLOW
Lighting the World's Waters

Lighting System Specifics

— Patent #7591564 —

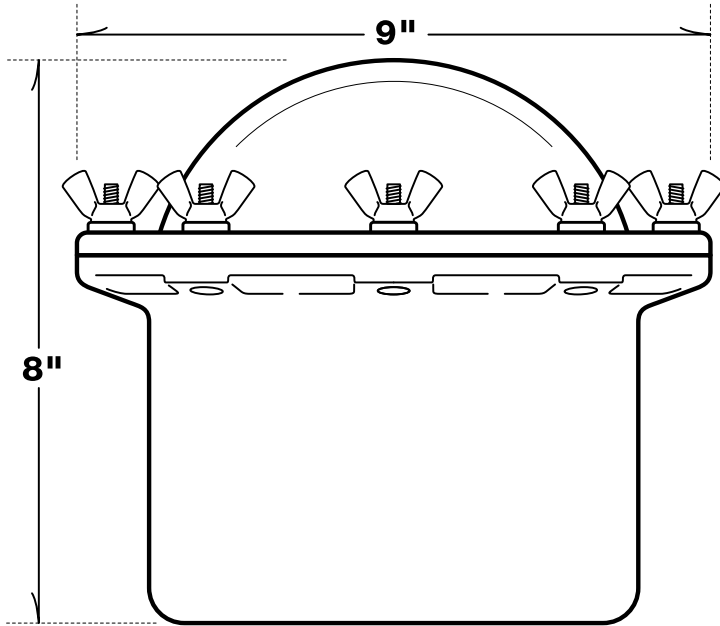

Lower Unit Housing:

Dimensions: Height 8" X Width 9"

Weight: 14Lbs.

Constructed with UL listed, non-corrosive and non-conductive components/materials.

Bulb/Lamp:

150Watt Metal Halide Lamp

Over 10,000 Lumens

Superior Color - Green, Blue,

Red, Orange, and Clear

Rated Average Life of 5500 Hrs.

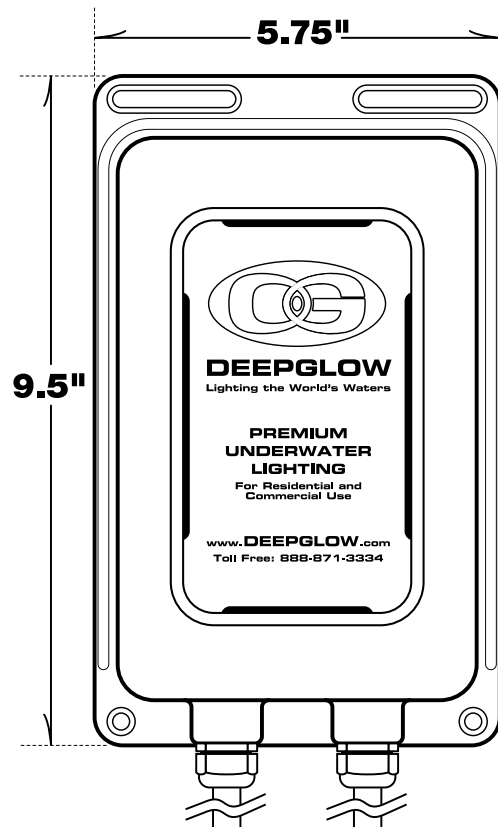

Ballast Enclosure:

Dimensions: 9.5"L X 5.75"W X 5"H

UV Resistant

UL Listed for Outdoor Usage

Must be mounted vertically

Operating System:

150W HID Electronic Ballast

Voltage: 120V to 240V AC nominal

Significant energy savings as compared to magnetic ballasts.

Safety Shut Down Features

UL Type 1 Outdoor Ballast

Max Lamp Distance from Ballast: 50'

Consumes less than 2 Amps

Phone: 727.234.1334 • Fax: 727.234.1335 • Toll Free: 888.871.3334

www.DeepGlow.com

Deep Glow Technologies, Inc.

Office Mailing Address:
PO Box 55055
St Petersburg, FL 33732

Warehouse Shipping Address:
4801 37th Street South
St Petersburg, FL 33711